



LBX Bulkhead Features

- ATEX, UKEX and IECEx approved for Zone 1 and 21 explosive gas and dust atmospheres
- Quick and easy to install, with fast fit cable terminations
- Two lumen outputs, 1,086 & 1,629lm
- Wide ambient temperature range of -50°C to +65°C (dependent on model type)
- Optimised thermal management for extending service life in extreme conditions.
- Fully optimised LED driver system for enhanced lifetime, performance, durability and efficiency
- CE and UKCA marked.
- Powder coated marine grade aluminium construction.
- Maintained and non-maintained emergency versions available.

ATEX INSTALLED LED LIGHTING

LBX BULKHEAD LBXE BULKHEAD LBXN BULKHEAD

ZONE 1

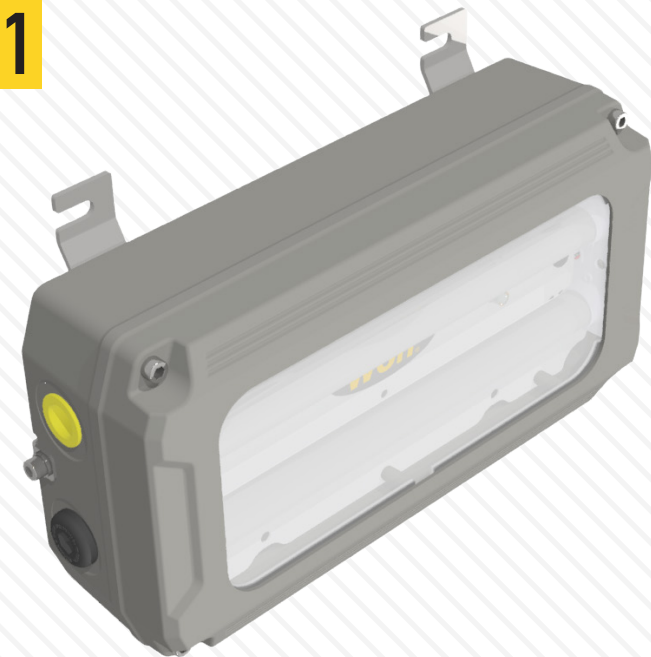

WOLF SAFETY LAMP COMPANY
Saxon Road Works, Sheffield, S8 0YA, England

Tel: +44 114 255 1051
E-mail: info@wolfsafety.com
Website: www.wolfsafety.com



LM-0257 - ISSUE 3
DF664

Authorised Representative [EU]2019R1020:
Authorised Representative Service, 77 Camden Street Lower, Dublin, D02 XE80, Ireland





Wolf Installed LBX Bulkhead
Installation, Operation and Maintenance Instructions
Please Retain - Read Before Use

EU Declaration of Conformity

This Wolf Installed LBX Bulkhead range meets all relevant provisions of the 2014/34/EU Explosive Atmospheres (ATEX Equipment) Directive by virtue of the issued EU type examination certificate, demonstrating compliance with all relevant harmonised standards and essential health and safety requirements.

The Wolf Installed LBX Bulkhead range is an efficient, robust and durable luminaire constructed of a cast aluminium enclosure protected by a powder coated finish. Models are available in a variety of input voltages. Approval is as Group II, Category 2 equipment for use in zone 1 & 2 potentially explosive gases, vapours, mists and dusts where the T4 temperature class/T80°C maximum surface temperature permits.

Approval Code: II 2 GD

Ex eb mb IIC T4 Gb
Ex tb IIIC T80°C Db IP66 / IP67
-50°C ≤ Ta ≤ +50 up to +65°C (dependent on model type)
-40°C ≤ Ta ≤ +59°C (emergency models)

Notified Body:
SGS FIMKO OY, P.O. Box 30 (Särkiniementie 3)
00211 HELSINKI, Finland.
Notified body number: **0598**

EU Type examination certificate:
ExVeritas 19 ATEX 0439X

Harmonised standards applied:
EN IEC 60079-0:2018, EN 60079-18:2015+A1:2017,
EN IEC 60079-7:2015+A1:2018, EN60079-31:2014

Wolf Installed LBX Bulkhead range also meet the requirements of the 2014/30/EU EMC Directive to the harmonised standards:
EN 55015: 2013 +A1:2015, EN 61547: 2009,
EN 61000-3-2:2019, EN 61000-3-3:2013 +A1:2019

The Wolf Installed LBX Bulkhead range is also Compliant with the 2011/65/EU RoHS Directive to the harmonised standard EN IEC 63000:2018.

Ingress protection: IP66 and IP67 to EN 60529:1992

This declaration is issued under the sole responsibility of Wolf Safety Lamp Company.

Alex Jackson – Managing Director,
Wolf Safety Lamp Company Ltd.,
Sheffield, UK.
Dated 01 April 2024.

UK Declaration of Conformity

The Wolf Installed LBX Bulkhead range meets all the statutory requirements of the Equipment and Protective Systems Intended for Use in Potentially Explosive Atmospheres Regulations 2016, UKSI 2016:1107 as amended by UKSI 2019:696 by virtue of the issued UKEX type examination certificate, demonstrating compliance with all relevant designated standards and essential health and safety requirements.

Approval code: II 2 GD

Ex eb mb IIC T4 Gb
Ex tb IIIC T80°C Db IP66 / IP67
-50°C ≤ Ta ≤ +50 up to +65°C (dependent on model type)
-40°C ≤ Ta ≤ +59°C (emergency models)

Approved Body:
SGS Baseefa Ltd, Rockhead Business Park,
Staden Lane, Buxton, SK17 9RZ, UK
Approval body number: **1180**

UK Type examination certificate:

ExVeritas 21 UKEX 0945X

Designated standards applied:
EN IEC 60079-0:2017, EN IEC 60079-7:2015+A1:2018,
EN 60079-18:2015+A1:2017, EN 60079-31:2014

The Wolf Installed LBX Bulkhead Luminaire also meets all the statutory requirements of the UK EMC Regulations 2016, UKSI. 2016:1091 as amended by UKSI 2019:696 to the following relevant designated standards:-
EN 55015: 2013 +A1:2015, EN 61547: 2009,
EN 61000-3-2:2019, EN 61000-3-3:2013 +A1:2019

The Wolf Installed LBX Bulkhead range is also compliant with the Restriction of the Use of Certain Hazardous Substances in Electrical and Electronic Equipment Regulations 2012, UKSI 2012/3032 to the designated standard EN IEC 63000:2018.

Ingress protection: IP66 and IP67 to EN 60529:1992

This declaration is issued under the sole responsibility of Wolf Safety Lamp Company.

Alex Jackson – Managing Director,
Wolf Safety Lamp Company Ltd.,
Sheffield, UK. Dated 01 April 2024.

IECEX Scheme Certification

Certificate number: **IECEX EXV 19.0002X**

Certification/Approval Code:

Ex eb mb IIC T4 Gb
Ex tb IIIC T80°C Db
-50°C ≤ Ta ≤ +50 up to +65°C (dependent on model type)
-40°C ≤ Ta ≤ +59°C (emergency models)

Standards applied: IEC 60079-0:2017, IEC 60079-7:2017,
IEC 60079-18:2017, IEC 60079-31:2013

Ingress protection: IP66 and IP67 to EN 60529:1992

LBXE-L-59-230-**-H0#	LBXE-L-59-230-**-L0#	LBXE-L-59-110-**-H0#	LBXE-L-59-110-**-L0#	LBXN-L-59-230-**-H0#	LBXN-L-59-230-**-L0#	LBXN-L-59-110-**-H0#	LBXN-L-59-110-**-L0#
200-277 V AC		100-140 V AC		200-277 V AC		100-140 V AC	
32W	24W	32W	24W	6W	6W	6W	6W
0.41A	0.26A	0.19A	0.14A	0.41A	0.26A	0.19A	0.14A
50 - 60 Hz							
>0.90							
1,629	1,086	1,629	1,086	0	0	0	0
25%: 407 50%: 815 75%: 1222	25%: 272 50%: 543 75%: 815	25%: 407 50%: 815 75%: 1222	25%: 272 50%: 543 75%: 815	25%: 407 50%: 815 75%: 1222	25%: 272 50%: 543 75%: 815	25%: 407 50%: 815 75%: 1222	25%: 272 50%: 543 75%: 815
90° (110° upon request)							
IP66 & IP67							
4.5kg							
T4							
T80°C							
-40°C							
59°C	59°C	59°C	59°C	59°C	59°C	59°C	59°C
4 x M20x1.5 threaded							
2.5A		2.0A		2.5A		2.0A	
150µs							
<10%							

Wolf Safety Lamp Co. reserves the right to change technical specifications without prior notice.
** to be replaced with the chosen beam angle. Default is 90°, 110° available on request.
to be replaced with either 1 for standard product or 2 for emergency sign version.

PATENTS

The lighting apparatus within these luminaires is covered by UK patent 2531689B & EU patent 3214365B1.

DISPOSAL OF WASTE MATERIAL

Disposal of packaging. Wolf products and any component parts should be carried out in accordance with applicable regulations, (WEEE).

The Wolf Safety Lamp Co. Ltd has a policy of continuous product improvement. Changes may be made to the above specification without notification, details are available on request. E&OE. All information has been gathered under laboratory conditions, the user must regard the values given as approximate. A copy of these instructions with any relevant revisions can be found at www.wolfsafety.com.

TECHNICAL DATA	LBXS-L-50-230-**-001	LBXS-L-59-230-**-001	LBXS-L-65-230-**-001	LBXS-L-50-110-**-001	LBXS-L-59-110-**-001	LBXS-L-65-110-**-001
Input Voltage Range	180-277 V AC			88-140 V AC		
Input Power	24W	16W		24W	16W	
Max. Input Current	0.15A	0.1A		0.35A	0.2A	
Frequency	50 - 60 Hz					
Power Factor	>0.90					
Lumen Output (Standard Operation)	1,629	1,086		1,629	1,086	
Lumen Output (Emergency Operation) 25%/50%/100%	N/A					
Beam Angles	90° (110° upon request)					
Ingress Protection	IP66 & IP67					
Weight	4kg					
Gas Temperature Class	T4					
Dust Surface Temperature	T80°C					
Lower Ambient Temp Limit	-50°C					
Upper Ambient Temp Limit	50°C	59°C	65°C	50°C	59°C	65°C
No. of Cable Entries	4 x M20x1.5 threaded					
Inrush Current (Peak)	2.5A			2.0A		
Inrush Current Duration	150µs					
Total Harmonic Distortion	<10%					

SERVICE LIFE & ROUTINE INSPECTION

Refer to the Safety, Operation, Installation & Maintenance section of this document before commencing any routine inspection work.

Frequency of maintenance will depend on the procedures in place on the site where the unit is installed, the installation location of the unit and the local operating conditions.

1. Check for mechanical damage and/or corrosion of enclosure, gaskets and fastenings. Damaged parts should be replaced.
2. Check for loose connections including internal and external earth connections. Tighten any loose connections.
3. Check for accumulations of dust or dirt and clean if necessary.
4. Check tightness of fixing, glands, blanking plugs etc to ensure IP rating is maintained.
5. Check for unauthorised modifications.
6. Check for any accumulation of moisture or internal contamination.

If any doubt that the luminaire remains safe and suitable in the installation location, contact Wolf for advice.

IMPORTANT: SPECIAL CONDITIONS FOR SAFE USE (X)

1. Cable entries into the equipment shall utilise suitably certified cable glands and shall provide a minimum degree of protection of IP66 or IP67 (dependent on the installation environment).
2. Unused cable entry apertures shall be closed with suitably certified blanking plugs which provide a minimum degree of protection of IP66 or IP67 (dependent on the installation environment).
3. When used in hazardous dust atmospheres, the equipment shall be installed so as to minimize the risk from electrostatic discharge. In particular, the equipment shall not be installed where there is a likelihood of there being fast moving particles over the surface of the equipment.
4. The equipment shall only be used with a power source having a prospective short circuit current which does not exceed 1500A.
5. Emergency versions: The end user must ensure that no hazardous atmosphere is present before replacing the battery pack. Only the specific replacement battery packs that are listed in the instruction manual may be fitted. The manufacturer shall specify only suitably rated battery packs as compatible. When transporting the battery pack through a potentially hazardous atmosphere the bare ends of the flying leads must be protected to IP30.

SAFETY, OPERATION, INSTALLATION & MAINTENANCE INSTRUCTIONS



1. Please read these installation, operation and maintenance instructions carefully before commencing installation or maintenance and retain for future use.
2. All Wolf LBX luminaires must be installed in accordance with EN IEC 60079-14 Electrical installations design, selection and erection standard, and maintained in accordance with EN IEC 60079-17 Electrical installations inspection and maintenance standard or the local hazardous area code of practice. If any parts are damaged or missing, the luminaire should be replaced in accordance with these instructions.
3. **IMPORTANT.** The installation area should be made safe, with no explosive atmosphere present and luminaires should be allowed to cool before commencing installation or maintenance work. Any work should be carried out by suitably qualified and experienced electricians only.

4. Do not change or alter any internal wiring.
5. **IMPORTANT.** No modifications are permitted to the LBX Bulkhead luminaires, unauthorized modifications or spare parts will invalidate certification.
6. The rating label must be checked to ensure the unit is being used within the correct ambient temperature and environmental conditions, and that the power supply is suitable.
7. In the UK the requirements of the 'Health and Safety at Work Act' must be met. Handling and electrical work associated with this product to be in accordance with the 'Manual Handling Operations Regulations' and 'Electricity at Work Regulations'.
8. Insulation resistance testing should be carried out in accordance with the latest applicable wiring regulations. Maximum insulation resistance test 500V DC. LEDs should be disconnected from the LED driver before performing this test.
9. Incoming mains cable should be suitable for use at the peak ambient temperature expected to be found where the unit is sited, plus 6°C.
10. Suitably certified ATEX/UKEX/IECEX M20x1.5 cable glands and/or stopper plugs must be used when installing the LBX range of luminaires. Glands must be suitable for the ambient temperature, cable type, diameter and intended environment to ensure correct IP rating. Threads must be parallel with a minimum thread length of 7.5mm. If you are unsure, please contact Wolf Safety.
11. Type C MCBs are recommended when installing these products.
12. If the luminaire is to be installed in an area of high vibration or shock conditions, consult with Wolf Safety.
13. Intense light output. Do not look directly at operational light fitting.
14. The luminaire enclosure contains non-metallic materials in the form of high-performance silicones used for the seals. The performance of these materials must be taken into consideration with respect to the atmosphere present in the hazardous area, and if in doubt, contact Wolf Safety.
15. The external faces of the luminaire may be cleaned with water containing a small amount of detergent only. Chemicals and oils may cause premature failure of seals.
16. Emergency models are supplied with the positive battery wire disconnected. When installing the luminaire, this wire must be connected to the driver as per wiring diagram on page 8.

OPENING

To allow access to the internals of the unit, the four bolts securing the front assembly must first be removed. An internal tether allows the lid to hang out of the way. The cover fixing bolts are retained in the cover.

When replacing the cover fixings, recommended torque for fixing screws is 4.5Nm.

WIRING

The unit contains two terminal blocks designated for mains field wiring connections. The terminal block poles are labelled + (Earth), N (Neutral), L1 (Switched Live) and L2 (Live).

For details of connections, see wiring diagrams.

MAINS TERMINALS

The mains terminals in this product have a current carrying capacity of 28A max.

Terminal wiring must be carried out in accordance with these instructions:

- Insulation strip length of 10-11mm
- Only one wire should be connected to each clamping point

Mains cable cross-section:

- 0.5-2.5mm² when using solid or stranded cable
- 0.5-2.5mm² when using an un-insulated bootlace ferrule
- 0.5-1.5mm² when using an insulated bootlace ferrule

The luminaire should be connected to earth. An external earth connection point is available for up to 4mm² connection. An internal earth point is also provided.

CABLE ENTRIES

There are four M20x1.5 threaded cable entries on the unit, to allow for loop in loop out or through wire arrangements. The through wiring in this product is 2.5mm².

The product is supplied with three of the cable entries blanked by suitably certified blanking plugs. The fourth entry is blanked with a dust cap. When wiring the unit, this dust cap must be replaced with a suitably certified cable gland.

LAMP MODULE REPLACEMENT

For lamp module replacement instructions, please refer to the instruction sheet supplied with the spare lamp module.

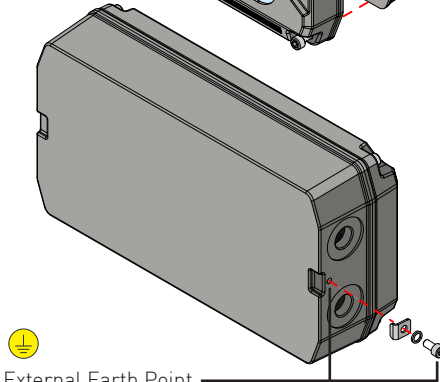
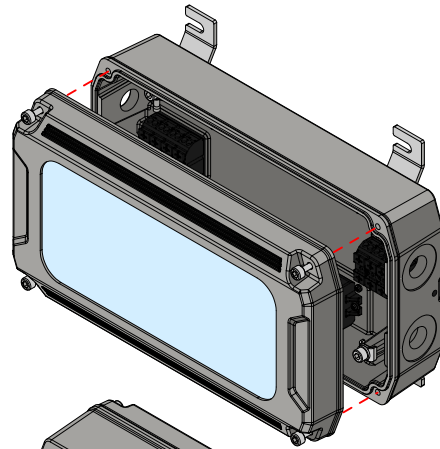

External Earth Point
Torque to 2.2Nm Max.

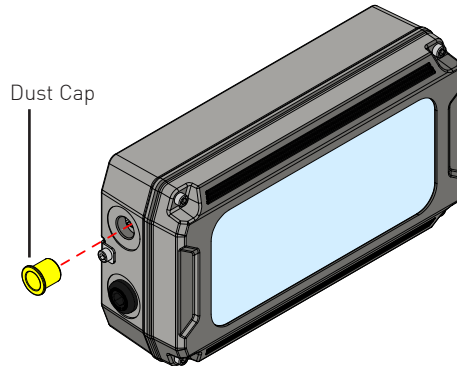

Dust Cap

WIRING DIAGRAM

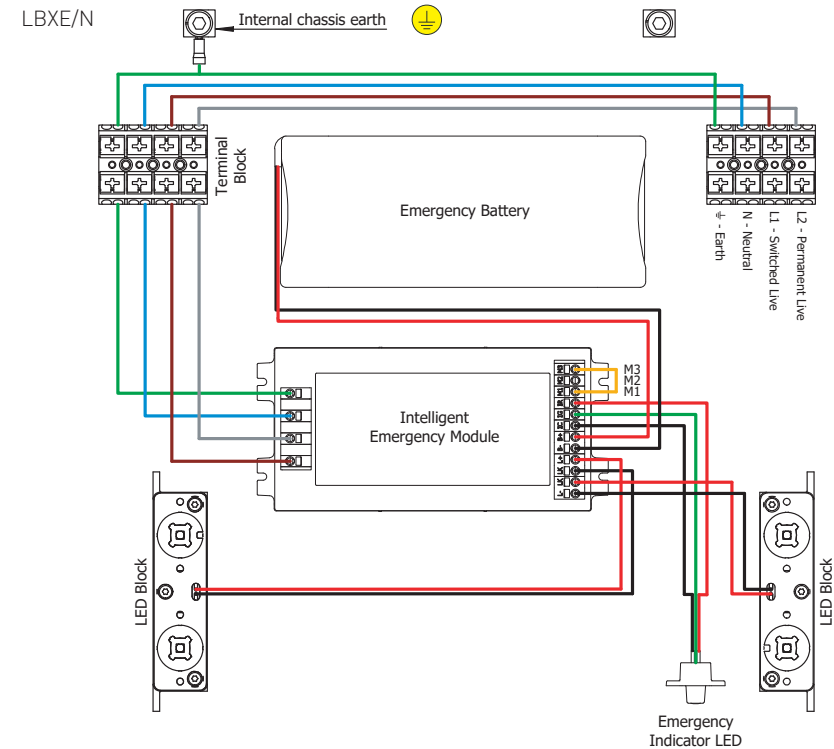
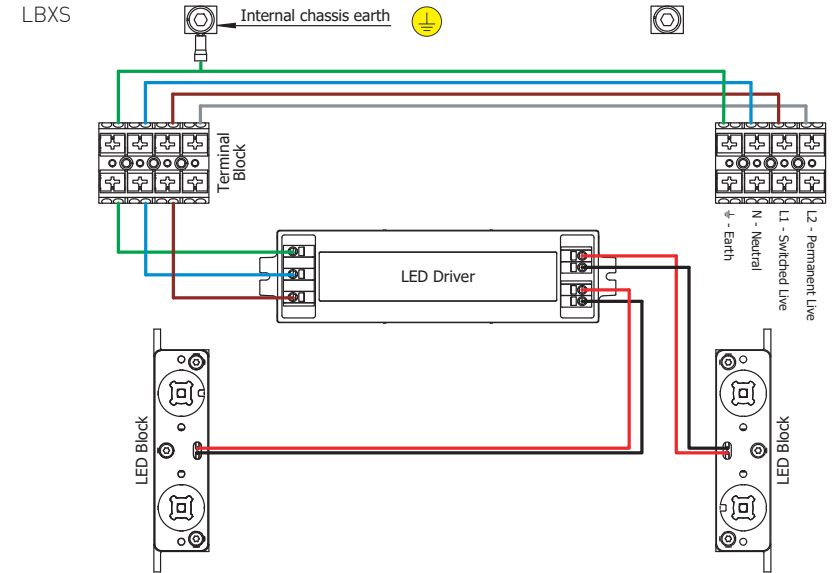

DIMENSIONS

LBXS, LBXE & LBXN

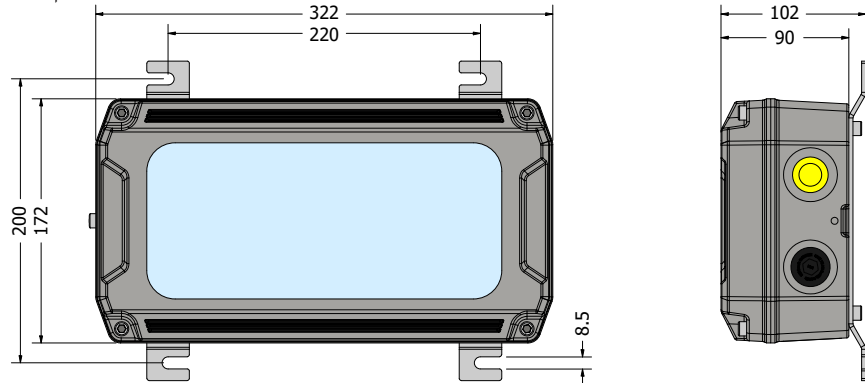

Dimensions are in mm.

MOUNTING

There are two mounting brackets supplied with the luminaire. These should be fixed to the back of the luminaire using the 4x M6 screws, washers and spring washers provided. The mounting brackets are designed to be secured using M8 fixings. A minimum of 2x fixings should be used to mount the luminaire.

If not using the mounting brackets provided, a distance of at least 8mm must be allowed between the back of the luminaire and any mounting surface to allow for proper cooling.

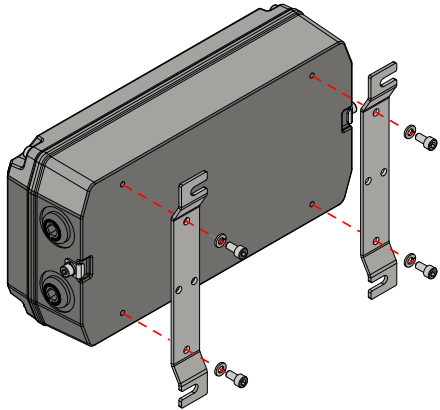

ACCESSORIES

The following mounting accessories are available to be purchased separately.

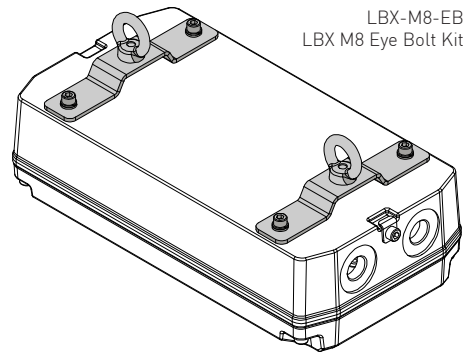

LBX-M8-EB
LBX M8 Eye Bolt Kit

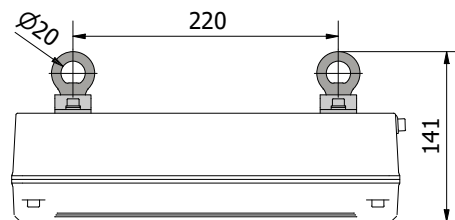

PATENTS

The lighting apparatus within these luminaires is covered by UK patent 2531689B & EU patent 3214365B1.

PAGES 4-6 DESCRIBE LBXE/N PRODUCTS ONLY

EMERGENCY VERSIONS

EMERGENCY BATTERY REPLACEMENT

Replacement of the battery may be required after several years of service to maintain the specified 3-hour emergency duration. This is typically 4 years, but battery life will be reduced if the fitting is subjected continuously to the highest ambient temperatures.

Warning – The battery pack is only to be replaced in a non-hazardous area and battery connections must be protected to IP30 before transporting through a hazardous area.

Replacement batteries must be obtained from Wolf Safety only, quoting part number LS-1072. LS-1072 batteries are supplied with suitably insulated wires complying with IP30 requirement.

For battery replacement instructions see below.

Warning - Do not allow battery wires to short together or contact a common ground, battery will short circuit and be damaged.

To remove the battery, the front panel assembly must be removed. The battery is situated on the rear of the front panel assembly. Next, remove the battery connections from the driver terminals. The spare battery pack is supplied with a piece of silicone tubing. This must be fitted over the wire ends on the old battery and secured in place with the cable ties that are also supplied with the spare battery pack.

Once the wire ends are protected, the battery can be removed from the front panel assembly. To release the battery, remove the 4x M3 retaining screws and slide the battery out of the bracket.

Slide in the new battery, replace and tighten the 4x retaining screws. Connect the new battery to the driver, making sure to observe the correct polarity. Refer to wiring diagrams for battery connection details.

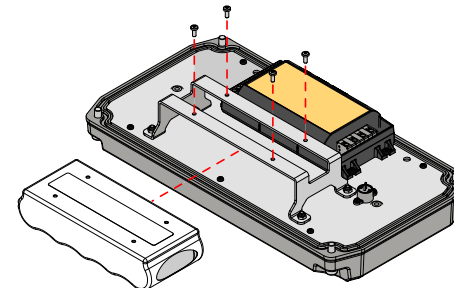

The LBX emergency can be wired as a maintained emergency or a non-maintained emergency product.

LBXE - Maintained Emergency
LBXN - Non-Maintained Emergency

On mains power failure, the LBXE/N switches over to battery power. The LBXE/N range is designed for a minimum 3-hour emergency light discharge at 25% light output. A green light on the gear tray indicates that the fitting is charging and operating correctly. See faults and indicator LED section for details.

For LBXE/N luminaires, an emergency exit sign kit is available to convert the luminaire into an emergency exit sign. The kit consists of self-adhesive universal exit graphics which are placed onto the front lens of the fitting.

BATTERY CHARGING

Start-up Charge: On start-up, the battery will be charged for a duration of 24 hours.

Intermittent Charge: Subsequently, the battery will be charged intermittently.

Voltage Limit: At low temperatures the battery charge voltage will be regulated at 8V.

Battery Connection Checking: The LBXE/N driver checks the connection to the battery is present.

Discharge Protection: The LBXE/N battery cells are protected by a deep-discharge protection circuit.

In the LBXE/N, the multifunctional connections on the driver allow user configuration of the duration and relative light output in emergency operation. A wire link between terminals sets the mode on start-up as shown in the table below. The link should only be changed when the unit is powered off and battery disconnected. The factory setting is 25%.

SETTING	WIRE LINK		
	M1	M2	M3
100% output, 1 hour duration			
50% output, 2 hours duration		—	
25% output, 3 hours duration	—		

Batteries become less effective at low temperatures. Therefore, at battery cell temperatures below 0°C, emergency light output will be set to 25% irrespective of the wire link

setting to ensure that illumination is provided for the required 3-hour duration.

At extreme high temperatures emergency light output is restricted to ensure that configured durations are met.

COMMISSIONING MODE

When shipped from the factory, the driver module will be in "Commissioning Mode". Commissioning Mode automatically brings the new battery up to optimum capacity by performing three cycles of a 24 hour charge followed by full discharge.

Should the module be used initially without a battery, it will stay in Commissioning Mode until the battery is connected. If commissioning is interrupted by a power failure, the unit will enter emergency mode and commissioning will continue when power returns.

Commissioning Mode is exited once commissioning has successfully completed but can be manually initiated at any time by powering the unit with no battery connected. This is recommended before a new battery is installed.

SELF TESTING FUNCTION

The LBXE/N has in-built automatic testing functionality to check and report emergency system health. Two types of test are automatically performed, Functional Tests and Duration Tests.

Functional Tests last 3 minutes and check that the battery, lamp and emergency driver function as they should. Duration Tests perform the same checks as Functional Tests but last an hour to verify that the battery capacity is still sufficient to meet the required emergency duration.

During a test, the system switches from mains to battery operation and powers the light source at 100% output. To minimise the risk of two luminaires performing a test simultaneously, the point at which the first functional test occurs is set to a random value between 1 and 8 days after the final commissioning discharge has completed. The first duration test occurs at random between 1 and 92 days after the final commissioning discharge has been completed. Future tests occur at regular intervals after this based on the schedule below.

Functional Test: every 7 days

Duration Test: every 91 days

The testing schedule and results are stored on power failure and the testing schedule resumes once mains operation returns.

If scheduled functional and duration tests overlap, the duration test takes priority and the functional test will be carried out following completion of the duration test and subsequent battery charge.

If power fails while a test is in progress, the unit will immediately enter emergency mode. The test will then be rescheduled for 24 hours after power returns. The batteries are not fully discharged even during a Duration Test to ensure that there is always capacity for emergency operation.

If the battery cell temperature is below 0 °C, tests will be delayed until the temperature increases. This is to prevent false test failures due to the reduced battery performance at low temperatures.

BATTERY STORAGE

Due to the self-discharge characteristics of the type of Nickel-Metal Hydride battery used in emergency models of this product, it is recommended that the battery is charged (for 16 hours) once a month.

It is imperative that the unit is charged every six months, otherwise permanent loss of capacity might occur. In this case, the unit will not function as an emergency luminaire and will indicate "Battery Fault".

This type of manual battery charging is only required when the product is in storage, prior to installation.

Recommended battery storage temp.: +5 to +25°C.

FAULTS & THE EMERGENCY INDICATOR LED

The system status is displayed on a multi-colour indicator LED which can be in any one of the following states:

PRIORITY	INDICATOR COLOUR	INDICATOR PATTERN	CONDITION
1	OFF	OFF	EMERGENCY MODE
2	RED	SOLID	LED FAULT
3	RED	SLOW FLASHING 0.5s ON, 0.5s OFF	BATTERY FAULT
4	RED	FAST FLASHING 0.1s ON, 0.1s OFF	CHARGING FAULT, CHARGING CURRENT INCORRECT
5	GREEN	SOLID	BATTERY CHARGED AND ALL SYSTEMS OPERATING CORRECTLY
5	GREEN	FAST FLASHING 0.1s ON, 0.1s OFF	BATTERY PERFORMING START-UP CHARGE AND NOT YET AT FULL CAPACITY
5	GREEN RED	ALTERNATE COLOURS 0.1s ON, 0.1s OFF	SYSTEM INITIALISING
5	GREEN RED	ALTERNATE COLOURS 0.5s ON, 0.5s OFF	COMMISSIONING MODE ACTIVE AND ALL SYSTEMS OPERATING NORMALLY
5	AMBER	SOLID	FUNCTION TEST IN PROGRESS
5	AMBER	SLOW FLASHING 0.5s ON, 0.5s OFF	DURATION TEST IN PROGRESS

Faults are displayed on the indicator LED for a period of 7 days following remedy. If a fault is present, the module will always still attempt to go into emergency mode. Faults are cleared on each power cycle when in commissioning mode. Some faults are identified as critical faults and disable the respective system to prevent damage or overheating. The critical faults are listed in the table below.

FAULTS	ACTION TAKEN BY MODULE
Battery disconnected, overvoltage, or charging overcurrent	Battery charging is disabled and the system enters an idle state from a charging perspective. If the critical error is cleared battery charging will resume starting with an initial charge for 24 hours. If the unit is in commissioning mode, the current commissioning cycle will be restarted.
LED open circuit, short circuit, overvoltage, or overcurrent	The currently-active LED driver is disabled. Re-enabling the appropriate LED driver is attempted every 30 seconds to check if the fault has been cleared.