



WTL ATEX Towerlite™ Features

- A fully certified Gas Zone 1 and 2 and Dust Zone 21 and 22 ATEX, IECEx and UKEX Hazardous Area lighting solution
- Powerful overhead illumination provides a large, wide spread of bright, uniform light for improved safety and enhanced productivity
- Extendable to a height of 5.5m for excellent high level illumination
- Up to 78,000 lumens of high quality, ultra bright light from 3 x LFX2 Floodlites
- IP66 - ideal for both indoor or outdoor use
- Fully adjustable with individual Floodlite rotation and tilt
- Supplied with H07RN-F cable for the input to and outputs from the Towerlite™
- Supplied with a fitted ATX, CEAG, Marechal or Stahl Ex plug
- Available in 110V or 230V versions
- Easy to manoeuvre and set up in minutes by a single operator
- Integral fork pockets for easy on-site transportation
- Options available with a socket for inter-connecting towers

WOLF SAFETY LAMP COMPANY
Saxon Road Works, Sheffield, S8 0YA, England

Tel: +44 114 255 1051
E-mail: info@wolfsafety.com
Website: www.wolfsafety.com



ATEX TOWERLITE™

WTL-575





Wolf ATEX Towerlite

Operation and Maintenance Instructions
Please Retain - Read Before Use

EU Declaration of Conformity

The Wolf Towerlite, incorporating three Wolf LFX2S-32 Floodlites, meets all relevant provisions of the 2014/34/EU Explosive Atmospheres (ATEX Equipment) Directive by virtue of the issued EU type examination certificate, demonstrating compliance with all relevant harmonised standards and essential health and safety requirements.

The Wolf Installed LFX range is an efficient, robust and durable luminaire constructed of a cast aluminium enclosure protected by a powder coated finish. Models are available in a variety of input voltages. Approval is as Group II, Category 2 equipment for use in zone 1 & 2 potentially explosive gases, vapours, mists and zone 21 and 22 potentially explosive dusts where the T4 temperature class/T110°C maximum surface temperature permits. The Towerlite Ex certified accessory allows for up to three Floodlites to be mounted at a maximum height of 5.5m. The lights can independently orientated and adjusted for optimum illumination. A number of different supply Ex plug types (ATX, CEAG, Marechal, Stahl) can be fitted as well as an optional Ex linkable socket.

Approval Code: II 2GD

Ex eb mb IIC T4 Gb
Ex tb IIIC T110°C Db IP66
-20°C ≤ Ta ≤ +49°C / +50°C
(dependent on model type)

Notified Body:
SGS FIMKO OY., P.O. Box 30 (Särkiniementie 3)
00211 HELSINKI, Finland.

Notified body number: **0598**

EU Type examination certificate:

ExVeritas19ATEX0586X

Harmonised standards applied:

EN IEC 60079-0:2018, EN60079-18:2015+A1:2017, EN IEC 60079-7:2015+A1:2018, EN60079-31:2014

Wolf Installed LFX Floodlight range also meets the requirements of the 2014/30/EU EMC Directive to the harmonised standards:

EN 55015: 2013 +A1:2015, EN 61547: 2009,
EN 61000-3-2:2019, EN 61000-3-3:2013 +A1:2019

The Wolf WTL towerlite is also Compliant with the 2011/65/EU RoHS Directive to the harmonised standard EN IEC 63000:2018.

Ingress protection: IP66 to EN 60529:1992

This declaration is issued under the sole responsibility of Wolf Safety Lamp Company.

Alex Jackson – Managing Director,
Wolf Safety Lamp Company Ltd.,
Sheffield, S8 0YA, UK.
Dated 01 January 2024.

UK Declaration of Conformity

The Wolf Towerlite, incorporating three Wolf LFX2S-32 Floodlites, meets all the statutory requirements of the Equipment and Protective Systems Intended for Use in Potentially Explosive Atmospheres Regulations 2016, UKSI 2016/1107 as amended by UKSI 2019/696 by virtue of the issued UKEX type examination certificate, demonstrating compliance with all relevant designated standards and essential health and safety requirements.

Approval code: II 2GD

Ex eb mb IIC T4 Gb
Ex tb IIIC T110°C Db IP66
-20°C ≤ Ta ≤ +49°C / +50°C
(dependent on model type)

Approved Body:
SGS Baseefa Ltd, Rockhead Business Park,
Staden Lane, Buxton, SK17 9RZ, UK

Approval body number: **1180**

UK Type examination certificate:

ExVeritas21UKEX0939X

Designated standards applied:

EN IEC 60079-0:2018, EN IEC 60079-7:2015+A1:2018,
EN60079-18:2015+A1:2017, EN60079-31:2014

The Wolf Installed LFX Floodlight range also meets all the statutory requirements of the UK EMC Regulations 2016, UKSI. 2016/1091 as amended by UKSI 2019/696 to the following relevant designated standards:-
EN 55015: 2013 +A1:2015, EN 61547: 2009,
EN 61000-3-2:2019, EN 61000-3-3:2013 +A1:2019

The Wolf WTL Towerlite is also compliant with the Restriction of the Use of Certain Hazardous Substances in Electrical and Electronic Equipment Regulations 2012, UKSI 2012/3032 to the designated standard EN IEC 63000:2018.

Ingress protection: IP66 to EN 60529:1992

This declaration is issued under the sole responsibility of Wolf Safety Lamp Company.

Alex Jackson – Managing Director,
Wolf Safety Lamp Company Ltd.,
Sheffield, S8 0YA, UK.
Dated 01 January 2024.

IECEx Scheme Certification

Certificate number: **IECEx EXV 19.0079X**

Certification/Approval Code:

Ex eb mb IIC T4 Gb
Ex tb IIIC T110°C Db
-20°C ≤ Ta ≤ +49°C / +50°C [dependent on model type]
Standards applied: IEC 60079-0:2011, IEC 60079-7: 2017,
IEC 60079-18: 2017, IEC 60079-31:2013
Ingress protection: IP66 to EN 60529:1992

WIRING DIAGRAM

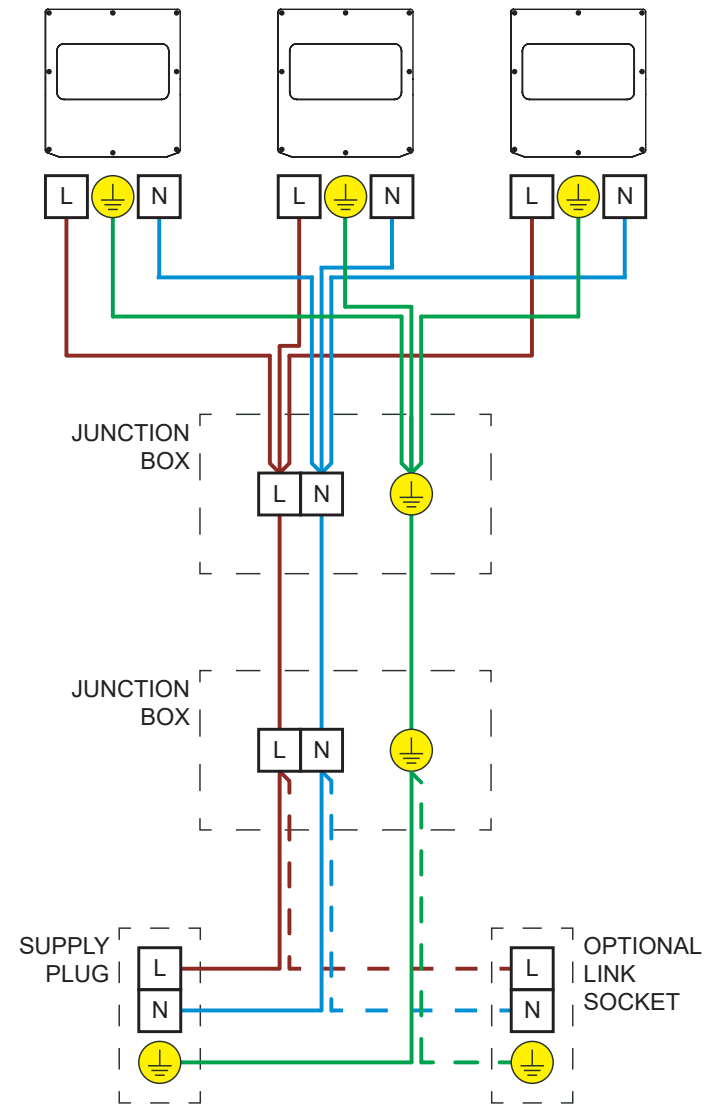

SPARE PARTS

Item No.	Part No.	Spare Part Description
1	LS-1110	Winding Handle
2	LS-1112	Anti-Static Wheels (set of 2)
3	LS-1114	Yellow Plastic Housing (2 part)
4	LS-1116	Plastic Housing Securing Screws (set of 6)
5	LS-1118	Outrigger Retention Plungers (set of 4)
6	LS-1120	Round Hatch
7	LL-1393	Local Earth Bonding Lead

DISPOSAL OF WASTE MATERIAL:

Disposal of packaging, parts and end of life products should be carried out in accordance with applicable regulations.

The Wolf Safety Lamp Co. Ltd has a policy of continuous product improvement. Changes in design details may be made without prior notice. Prices and design are subject to alteration without notice. All products sold are subject to our conditions of sale. A copy of these instructions with any relevant revisions can be found at www.wolfsafety.com.

IMPORTANT: SPECIAL CONDITIONS FOR SAFE USE (X)

1. Cable entries into the equipment shall utilise suitably certified cable glands and shall provide a minimum degree of protection of IP66 or IP67 (dependent on the installation environment).
2. Unused cable entry apertures shall be closed with suitably certified blanking plugs which provide a minimum degree of protection of IP66 or IP67 (dependent on the installation environment).
3. When used in potentially hazardous dust atmospheres, the equipment shall be installed so as to minimize the risk from electrostatic discharge. In particular, the equipment shall not be installed where there is a likelihood of there being a static generating mechanism, such as steam generation or fast-moving particles over the surface of the equipment.
4. The equipment shall only be used with a power source having a prospective short circuit current which does not exceed 1500A.
5. LFX2S-32 floodlights shall not be mounted with the cable entry at the top. Additionally, the manufacturer may mark this version with a reduced upper ambient limit for use in uplighting applications.*

* The upper ambient temperature for the tower light assembly has been reduced to account for this temperature limitation.

SAFETY, OPERATION & MAINTENANCE INSTRUCTIONS



1. Please read these safety, operation and maintenance instructions carefully before commencing use or maintenance and retain for future use.
2. **IMPORTANT.** The work area should be made safe and luminaires should be allowed to cool before commencing maintenance work. Any maintenance work should be carried out by suitably qualified and experienced electricians only.
3. **IMPORTANT.** No modifications are permitted to the Towerlite or Floodlites, unauthorised spare parts or modifications will invalidate certification.
4. Do not change or alter any wiring. Cables have been assessed and chosen for compliance to the

specific ambient temperature range. Insulation resistance testing should be carried out in accordance with the latest applicable wiring regulations. Maximum insulation resistance test 500V DC. LEDs should be disconnected from the circuit before performing this test.

5. The rating label on the Towerlite must be checked to ensure the unit is being used within the correct ambient temperature and environmental conditions, and that the power supply is suitable.

6. It is recommended that Type C MCBs are used to the supply power the Towerlite to prevent nuisance tripping. 110V - 10A / 230V - 6A per Towerlite.

7. The LFX Floodlites are photobiological safety risk group 1 - No photobiological hazard under normal behavioural limitations. Do not look directly at operating light fittings.

8. The LFX Floodlite enclosure incorporates silicone seals, the user must ensure suitability of the atmosphere the product will be used in. Clean only with water and a small amount of mild detergent.

9. All external Towerlite wiring uses H07RN-F cable.

10. Ensure the Towerlite is secured in place when transporting between sites, lower jacks without extending outriggers for additional stability. The Towerlite must remain upright, lowering onto its side will damage mast interconnections.

11. Use the incorporated fork pockets/wheels to locally transport the Towerlite.

12. Avoid the risk of electrostatic discharge:- clean the Towerlite housing with a damp cloth, avoid siting near fast moving streams of air or steam.

13. When deploying the Towerlite, site the unit on firm, level ground, avoiding any overhead hazards. Manoeuvre into position using the T-handle and wheels, orientating the centre Floodlite to point in the required direction. The outer two Floodlites can then be rotated and all Floodlites adjusted for tilt as required using threaded bridle handles.

14. Before raising the mast, fully extend and lock the outriggers, engage the jacks to raise the Towerlite wheels off the ground and level the unit.

15. Raise the Towerlite mast using the manual winding handle provided, stop winding once the red line is visible on the mast. Raising further will result in damage.

16. To energise the Towerlite, open the black hatch in the housing, connect the Ex plug to a correctly rated power supply. Observe maximum current limits on cable and connectors when powering both non-linkable and individual/multiple linkable units.

17. De-energise before moving the Towerlite or raising/lowering the mast.

18. The Ex plug supplied is rated IP66 only when correctly connected to a compatible Ex socket or coupler. Ensure the Ex plug is protected from water ingress and dirt/dust when not in use, store inside the yellow Towerlite housing with the access hatch closed. For Towerlite units that include a linkable Ex socket, the Ex plug for the unit can be fitted and latched into this for storage to maintain the IP rating. Ensure the Ex socket lid is latched shut when not in use.

19. Lower the Towerlite mast fully for wind speeds greater than 40mph.

20. To maintain the self-greasing system on the mast mechanism the tower should be raised / lowered every 3 months, users should record this in a service log to support any potential warranty claim. Dust or grit may affect mast mechanism functionality.

21. Tower unit has a zinc coated steel construction, any signs of surface oxidation will not affect operational performance or ongoing functionality.

22. It is the user's responsibility to ensure there is no potential difference between the earth supply to a WTL Towerlite unit and the local earth in the work area. Where this is not possible the equipment should be securely earth bonded to metalwork in the immediate vicinity of where the Floodlight is being used. A flexible cable is recommended (6mm² minimum), connected to the earth grounding point on the Towerlite chassis. The Towerlite must be de-energised during connection or disconnection of the local earth bond.

23. LFX Floodlites and cable should be inspected prior to each use for visible signs of damage. Particular attention should be paid to gland and socket entries. Damaged Floodlites should be removed from the hazardous area and repaired before being put back in service.

24. For maintenance of the LFX Floodlites, refer to the LFX Floodlight instruction manual.

TECHNICAL INFORMATION

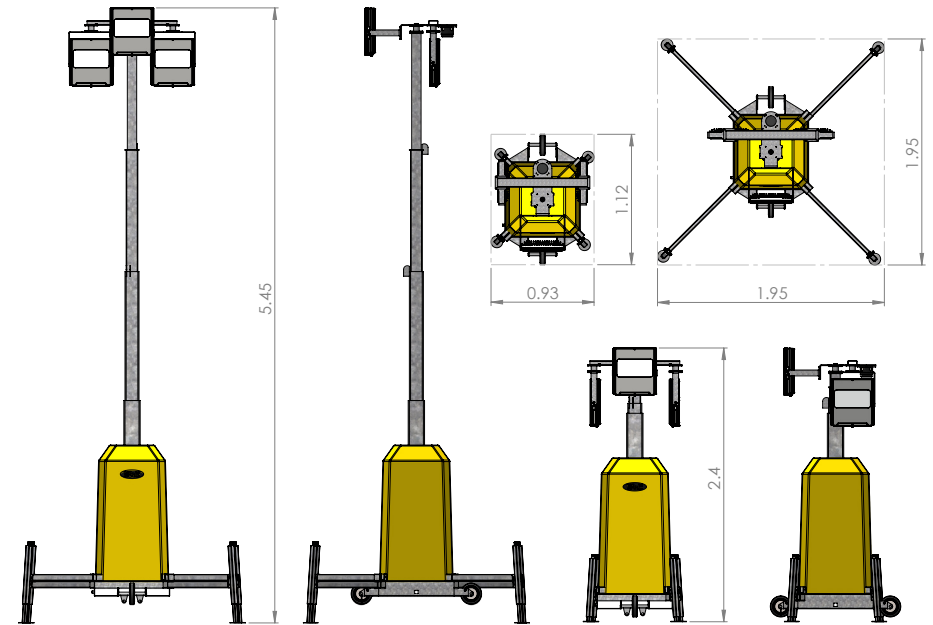

TECHNICAL DATA	WTL-575/110	WTL-575/230
Input Voltage Range	88-140 V AC	180-277 V AC
Input Power	3x 180W	
Frequency	50 - 60 Hz	
Power Factor	>0.95	
Lumen Output	77,796 lumens (25,932 lumens per LFX Floodlight)	
Light Source	3 x Wolf LFX2 Floodlites (32 LEDs per light)	
Colour Temperature	5000K	
Beam Angle	62°	
Ambient Temperature	-20°C to +50°C	-20°C to +49°C
Ingress Protection	IP66	
Plug Options	ATX, CEAG, Marechal, Stahl	
Dimensions	Mast height - 5.5m when fully extended	
Weight	Approximately 320kg (including lights)	
Inrush Current Duration	150µs	
Total Harmonic Distortion	<15%	

